

BURNER CONTROLLER **(MODEL 722 – FR – P10 -PP)**

GENERAL

The Burner Controller (Model 722-FR-P10 - PP) is designed for safe start-up and continuous monitoring of GAS FIRED burners used in various applications, such as, Furnaces, Dryers, Boilers, etc. The Controller uses state of the art microprocessor based design to provide reliable and precise sequence operation, with easy to follow visual indications.

The Controller is housed in an ABS plastic enclosure with over all size of 70 mm (L) x 110 mm (B) x 105 mm (H). The enclosure consists of a Base and a Plug-in Controller module, which facilitates easy replacement at the site.

The controller senses the flame using FLAME ROD. Hence, it is suitable only for Gas Flame. The Controller provides a high voltage for the Flame Rod (Electrode). The flame Rod is immersed in the flame to be sensed. The current thus generated by the flow of electrons through the flame from Flame Rod to the ground is detected by the controller.

Note: Please refer to the enclosed “FLAME ROD INSTALLATION INSTRUCTIONS”, to ensure reliable and trouble free operation of Flame Rod based controllers.

SEQUENCE SPECIFICATIONS:

The power supply (230V AC, 50 Hz) is connected to the Burner Controller across terminals 1 & 2. In practice, a typical installation may have Control switch.

The Sequence Controller is energised when the supply is available at Terminal 1. The Sequence will start provided the following conditions are met:

The Controller will **WAIT** for the Safety / Control Loop between Terminals 4 and 5 to close. Safety / Control Loop is typically formed by Thermostat (TC)

This condition is indicated by Slow Flashing of the Safety LED

<u>Step No.</u>	<u>Time in Seconds</u>	<u>Operation</u>	<u>Symbol Ref</u>	<u>Terminal Ref</u>
1	T1 = 0	Blower ON	B	6
2	T2 = T1 + 10	Ignition ON First Solenoid OPEN	I V1	9 7
3	T3 = T2 + 4	Ignition OFF	I	9

Linear Systems

Ph/Fax: +91 22 25576002

<u>Step No.</u>	<u>Time in Seconds</u>	<u>Operation</u>	<u>Symbol Ref</u>	<u>Terminal Ref</u>
If Flame is present				
4A	T4 = T3 + 6	Second Solenoid OPEN <i>Normal Operation</i>	V2	8
If Flame is NOT present				
4B	T4 = T2 + 3	All Outputs OFF LOCK OUT ON <i>Slow Flashing of Flame LED</i>	L	10

Note: In the case of Flame Rod, the time constant to establish steady Ionisation Current is about 3 s. Hence, 3 s delay is necessary for reliable sensing of the flame, after Ignition is switched OFF. *For faster response, use of UV based Controller is recommended.*

LOCK OUT is initiated under following conditions:

1. False Flame in Step 1 - *indicated by Fast Flashing of Flame LED*
(Possible Causes – Flame Rod touching the Burner/Ground or Leaky valve)
2. Flame Failure in Step 3 - *indicated by Slow Flashing of Flame LED*
(Possible Causes – Blocked Fuel line, Faulty Ignition Transformer, etc)

The Lockout can be reset by pressing the Reset Push Button on the Controller OR externally by a Reset Push Button connected across Terminals 3 & 4, as shown in the schematic. *A momentary interruption of the Supply will also Reset the Controller.*

RETRIAL

If a Flame Failure occurs during Normal operating condition, then the Controller initiates a Retrial from Step 2. **LOCKOUT** is initiated if the flame is not present after Retrial.

Note: **RETRIAL is not recommended** for gas installation due the possibility of back fire and explosion. Hence, this feature is normally disabled, unless otherwise specified by the Customer. Please refer to ORDERING INFO for details.

SAFETY INTERLOCK & POST-PURGE

The Safety / Control circuit is typically formed by connecting Pressure Switch and Temperature Controller Output Contacts, etc in series, across terminals 4 & 5. All contacts must be potential free Normally Open contacts. When any of the contacts in Safety Loop is OPEN, both Fuel Valve and Ignition supply is turned OFF. The Blower will stop after a Post Purge time of 10 seconds. **Blower can be connected to terminal 4 for continuous operation.**

The Controller will now wait for safety Loop to close. This condition is indicated by Slow Flashing of the Safety LED. When the Safety Contacts close, the Sequence restarts automatically from Step 1.

Linear Systems

Ph/Fax: +91 22 25576002

WIRING DIAGRAM

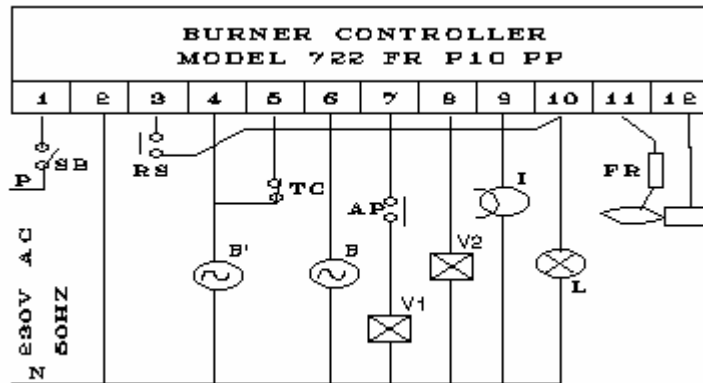

P – Phase

N – Neutral

TC – Temp. Control

SB – Safety Limit Thermostat

AP – Air Pressure Switch

B – Burner Motor / Blower

V1 – First Fuel Sol Valve

V2 – Second Fuel Sol Valve

I - Ignition

RS – Reset Push Button

L - Lockout / Alarm

FR – Flame Rod

A Earth wire from the Burner should be connected to the Burner Ground (Terminal 12) of the Controller. The Flame Rod must be properly insulated while mounting. Use HV cable for connecting Controller and the Flame Rod.

Note: The Output relay contacts are rated at 3 A. However, the total current from the Controller should not exceed 3 A. A blown Fuse indicates a fault in the panel or in the external wiring. Please check the external wiring before replacing the fuse.

IMPORTANT INSTRUCTIONS FOR FLAME ROD INSTALLATIONS

The Burner Controller senses the flame by means of a metal rod (called the Flame Rod or Flame Electrode) immersed in the flame. The Controller provides the supply voltage (230V AC) to the flame rod. When the flame is present, there is a small electron flow into the flame rod. In other words, the flame essentially acts a rectifier with the Flame Rod as anode. The Controller is designed to measure the effective DC current flowing from flame rod to the ground.

In a typical burner installation, there is always a small AC leakage current, mainly due to the insulation leakage. The Controller is designed to be immune to such small leakage currents. However, substantially large AC leakage currents (due insulation degradation or insulation failure) will result in the flame not being sensed, since it will reduce the effective DC current value. The Controller will initiate a LOCKOUT under such conditions, even if the flame is present. Hence, the Controller will also go to LOCKOUT, if the Flame Rod touches the Burner metal surface or Ground.

Hence, it is important that the Flame Rod is properly insulated while mounting. A HV cable with good insulation must be used for connecting Flame Rod to the Controller. Also, an insulated wire from the Burner surface must be connected directly to the Ground Terminal at the Controller. The cable insulation must be adequately rated for the ambient temperature present at the installation, and must have very low leakage.

It has been observed that that the magnitude of effective DC current flow (also, called Ionisation Current) is affected by the following factors.

1. The Flame rod must be immersed in the blue outer core of the gas flame.
2. The Burner Surface Area touching the flame must be sufficiently large. In practice it must be at least 4 to 5 times the surface area of the flame rod touching the flame. If the Burner Surface Area touching the flame is insufficient, then additional plates can be welded to burner metal frame to increase the area.
3. The flame rod and the burner surface must always be in contact with the flame. This is an important issue when the flame has a tendency to move around. In such cases, flame rod mounting will play a crucial role for obtaining reliable flame signal.
4. Lack of sufficient air for proper combustion will result in low values of ionisation current. It is essential to maintain good Air-Fuel Ratio for proper sensing of flame.
5. The Flame Rod must be clean and free of carbon deposits. Hence, it is important to clean the Flame Rod at regular intervals.

It is possible to measure the effective DC current, by connecting a DC micro-ammeter between the Flame Rod Output Terminal on the Controller and the Flame Rod. In a typical installation, one can expect DC currents in excess of 15 to 20 micro-amps. For reliable flame sensing, the DC current flow must be at least 4 to 5 micro-amps.